

Stichart 503

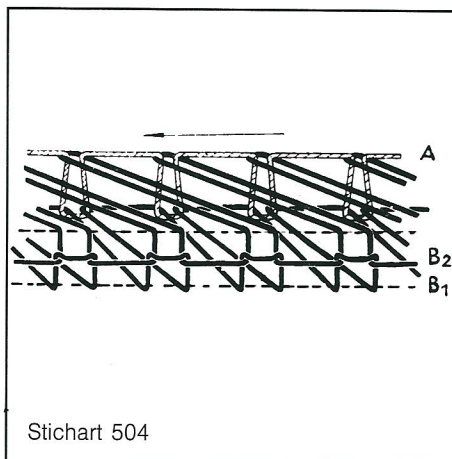

Stichart 504

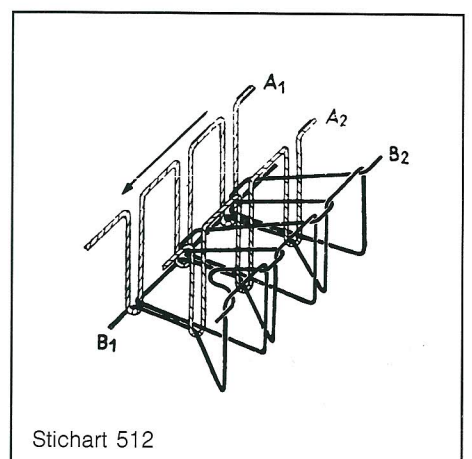

Stichart 512

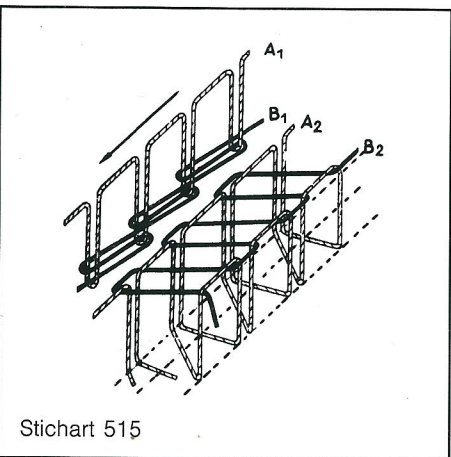

Stichart 515

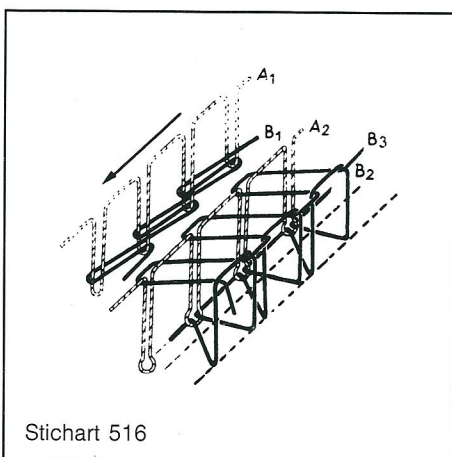



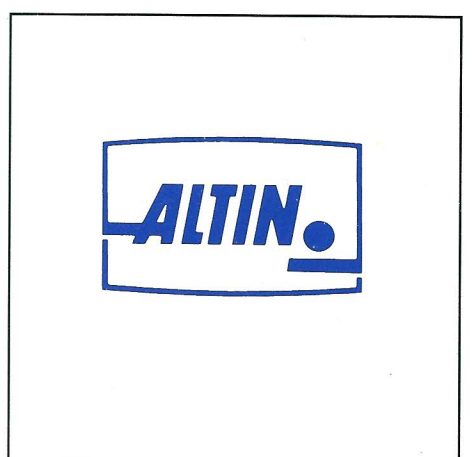

Stichart 516

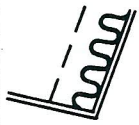

Überwendlich-Nähmaschinen Baureihe 8515

Overlock Sewing Machines, Series 8515

										
	1,6 mm	2,0 mm	2,5 mm	3,2 mm	4,0 mm	5,0 mm				
8515 / 010 / ... / 011 / ... / 012 / ... / 014 / ...				301 304 301 304	300 303 300 303	299 302 299 302	503	1	—	2
8515 / 050 / ... / 052 / ...				227 227	226 226	225 225	504	1	—	3
8515 / 060 / ... / 061 / ... / 062 / ... / 064 / ...			240 342 240 342	239 341 239 341	238 340 238 340	237 339 237 339	504	1	—	3
8515 / 070 / ... / 071 / ... / 072 / ... / 074 / ...			240 342 240 342	239 341 239 341	238 340 238 340	237 339 237 339	504	1	—	3
8515 / 080 / ... / 081 / ... / 082 / ... / 084 / ...				231 349 231 349	230 348 230 348	229 347 229 347	504	1	—	3
8515 / 090 / ... / 092 / ...				355 355	354 354	353 353	504	1	—	3
8515 / 100 / ... / 101 / ... / 102 / ... / 104 / ...	206 252 206 252	205 251 205 251	204 *(236) 250 *(274) 204 *(236) 250 *(274)	203 *(235) 249 *(273) 203 *(235) 249 *(273)	202 *(234) 248 *(272) 202 *(234) 248 *(272)	201 *(233) 247 *(271) 201 *(233) 247 *(271)	504	1	—	3
8515 / 110 / ... / 111 / ... / 112 / ... / 114 / ...			210 256 210 256	209 255 209 255	208 254 208 254	207 253 207 253	504	1	—	3
8515 / 120 / ... / 121 / ... / 122 / ... / 124 / ...			315 319 315 319	314 318 314 318	313 317 313 317	312 316 312 316	504	1	—	3
8515 / 130 / ... / 132 / ...				227 227	226 226	225 225	504	1	—	3
8515 / 141 / ... / 144 / ...						361 361	503	1	—	2
8515 / 410 / ... / 413 / ...				311 352	310 351	309 350	512	2	2,5	4

Bestell-Nr.



Number to order

Numéro à commander

номер заказа

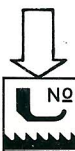
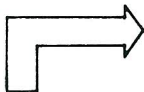



8515/ /

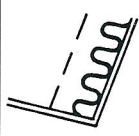

0	<input type="checkbox"/>	<input type="checkbox"/>	<input type="checkbox"/>
1		<input type="checkbox"/>	<input type="checkbox"/>
2	<input type="checkbox"/>		<input type="checkbox"/>

Sicherheitsnaht-Nähmaschinen Baureihe 8515

Safety Seam Sewing Machines, Series 8515

								
	2,5 mm	3,2 mm	4,0 mm	5,0 mm				
8515 / 610 / ... *	216	215	214	213	515	2	2,0	4
/ 611 / ... *	262	261	260	259				
/ 612 / ... *	216	215	214	213				
/ 614 / ... *	262	261	260	259				
8515 / 620 / ... *	220	219	218	217	515	2	3,2	4
/ 621 / ... *	266	265	264	263				
/ 622 / ... *	220	219	218	217				
/ 624 / ... *	266	265	264	263				
8515 / 630 / ... *	224	223	222	221	515	2	5,0	4
/ 631 / ... *	270	269	268	267				
/ 632 / ... *	224	223	222	221				
/ 634 / ... *	270	269	268	267				
8515 / 660 / ...	246	245	244	243	516	2	3,2	5
/ 661 / ...	346	345	344	343				
/ 662 / ...	246	245	244	243				
/ 664 / ...	346	345	344	343				
8515 / 680 / ...	216	215	214	213	516	2	2,0	5
/ 681 / ...	262	261	260	259				
/ 682 / ...	216	215	214	213				
/ 684 / ...	262	261	260	259				
8515 / 690 / ...	220	219	218	217	516	2	3,2	5
/ 691 / ...	266	265	264	263				
/ 692 / ...	220	219	218	217				
/ 694 / ...	266	265	264	263				
8515 / 700 / ...	224	223	222	221	516	2	5,0	5
/ 701 / ...	270	269	268	267				
/ 702 / ...	224	223	222	221				
/ 704 / ...	270	269	268	267				
8515 / 710 / ...	323	322	321	320	516	2	3,2	5
/ 711 / ...	327	326	325	324				
/ 712 / ...	323	322	321	320				
/ 714 / ...	327	326	325	324				
8515 / 720 / ...	331	330	329	328	516	2	5,0	5
/ 721 / ...	335	334	333	332				
/ 722 / ...	331	330	329	328				
/ 724 / ...	335	334	333	332				
8515 / 730 / ... *	323	322	321	320	515	2	3,2	4
/ 731 / ... *	327	326	325	324				
/ 732 / ... *	323	322	321	320				
/ 734 / ... *	327	326	325	324				
8515 / 740 / ... *	331	330	329	328	515	2	5,0	4
/ 741 / ... *	335	334	333	332				
/ 742 / ... *	331	330	329	328				
/ 744 / ... *	335	334	333	332				

Bestell-Nr.

Number to order

Numéro à commander

номер заказа

8515/ /

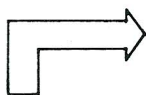

0



1



Symbole für technische Merkmale

Key to symbols

Légende des symboles

Символы для технических признаков

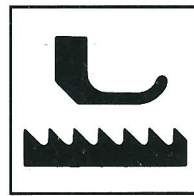

Untertransport
Bottom feed
Entraînement inférieur
нижний транспорт

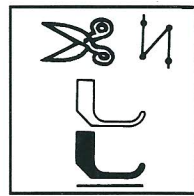

Mechanisierungseinrichtungen
Mechanization devices
Dispositifs de mécanisation
устройства механизации

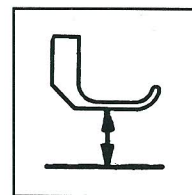

Nähfußhub (mm)
Presser foot lift (mm)
Levee du pied presseur (mm)
подём лапки (мм)

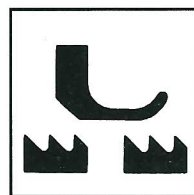

Differentialtransport
Differential feed
Entraînement différentiel
дифференциальный транспорт

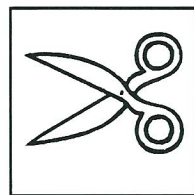

Fadenabschneider
Thread cutter
Coupe-fil
устройство для обрезки ниток

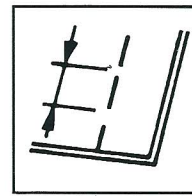

Stichlänge (mm)
Stitch length (mm)
Longueur de point (mm)
длина стежка (мм)

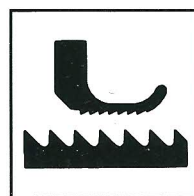

Untertransport, Obertransport, unabhängig voneinander einstellbar
Bottom feed, top feed adjustable independently of each other
Entraînement inférieur, entraînement supérieur ajustable séparément
нижний и верхний транспорт, устанавливаемые независимо друг от друга

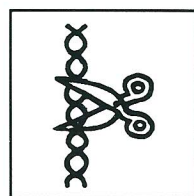

Leerkettentrenner
Chain cutter
Coupe-chaînette
устройство для обрезки цепочки ниток

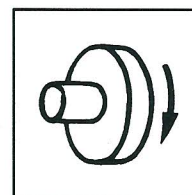

max. Stichleistung (Stiche/min.)
Maximum speed (stitches/min)
Vitesse maximale (points/mn)
макс. скорость шитья (стежки в мин)

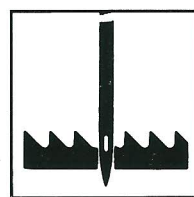

Unter- und Nadeltransport
Bottom and needle feed
Entraînement inférieur et par aiguille
нижний и игольный транспорт

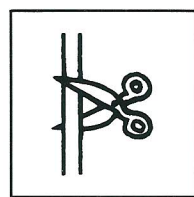

Querschneider
Cross cutter
Coupe transversal
устройство для поперечной обрезки

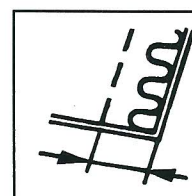

Gesamtnahtbreite
Total seam width
Largeur totale de la couture
общая ширина

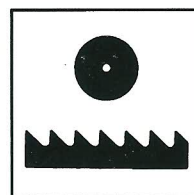

Untertransport mit Rollfuß
Bottom feed with roller presser
Entraînement inférieur avec pied rouleur
нижний транспорт с роликовой лапкой



Nähfußhub mittels Hilfsenergie
Presser foot lift by auxiliary energy
Levee du pied presseur par énergie auxiliaire
подём лапки при помощи вспомогательной энергии

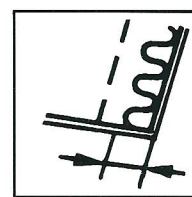

Überwendlichnahtbreite
Overlock seam width
Largeur de la couture surjetée
ширина обмещочного шва

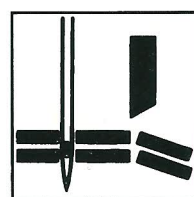

Kantenschneideinrichtung
Edge cutter
Coupe-bord
устройство обрезки края

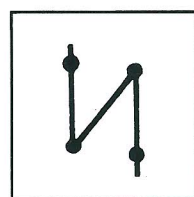

Verriegelungsautomatik
Automatic back-tacking
Dispositif automatique pour coudre les arrêts
автоматика для закрепки шва

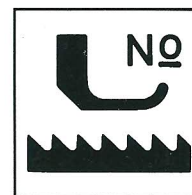

Nummer der Nähgarnitur
Sewing set number
Numéro de l'ensemble de couture
номер швейной гарнитуры

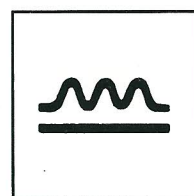

Transport-Momentverstellung
Feed-instantaneous adjustment
Entraînement ajustage instantané
моментальная перестановка транспорта

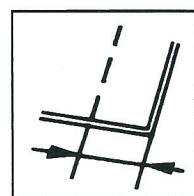

Schneidabstand (mm)
Trimming margin (mm)
Distance de coupe (mm)
расстояние от линии разреза

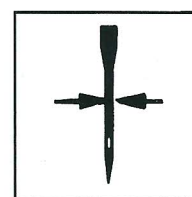

Nadelsystem, Nadeldicke
Needle system, needle gauge
Système d'aiguille, épaisseur d'aiguille
система иглы
толщина иглы

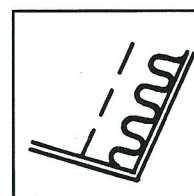

Stichtyp
Stitch typ
Genre de point
вид стежка

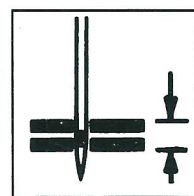

max. Nähgutdicke (mm)
Maximum material thickness (mm)
Épaisseur max. de la matière à coudre (mm)
макс. толщина пошивочного изделия (мм)

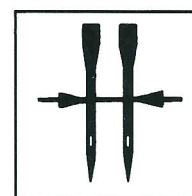

Nadelabstand (mm)
Needle distance (mm)
Écartement des aiguilles (mm)
расстояние между иглами (мм)

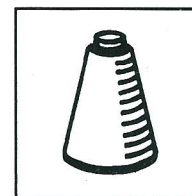

Fadenanzahl
Thread quantity
Nombre des fils
количество игл